



## PROJECT-BASED LEARNING: SAE MICRO-ELECTRIC

### Description

The first objective of the competition is to design and build a dry cell powered vehicle (battery supplied) to race up a fixed incline while pulling a six ounce weighted trailer (supplied).

The second objective is to be the first to pass the finish line with the trailer in tow. In addition, a four-minute presentation and a one-page, typewritten report about the vehicle is optional.

### Deliverables

- Working Micro-Electric Vehicle
- Permission Slip
- One Page Paper

### Requirements

For the competition, ideal submissions will meet the following requirements:

1. Tested and Working Micro-electric Vehicle
2. Permission slip must be signed and returned
3. One page paper must be typed and submitted by deadline
4. Teams must prepare a four minute presentation



### **VEHICLE SPECIFICATIONS (Constraints)**

- The vehicle must fit in a box (5) inches wide by (8) inches long by (6) inches high
- Only one AA alkaline battery may be used for propulsion and lighting
- Vehicle must have (4) wheels
- Vehicle may be (2) or (4) wheel drive
- No tank type treads allowed
- Vehicle must have two working headlamps
- (1) or (2) switches must be used to control propulsion and headlamps
- Headlights must be easily visible in full daylight
- Switch(s) must be mounted on top or rear of vehicle and must be accessible without disassembly. Failure to comply with this rule is grounds for a DNF in the performance competition
- If electronics are used, test points must be accessible for judges to verify that no stored energy is present. Teams are requested to provide a wiring schematic to document test/discharge points.
- Battery must be accessible from outside vehicle (no disassembly required). Failure to comply with this rule is grounds for a DNF in the performance competition
- A battery holder of some type must be used (no soldering, taping, gluing allowed)
- A trailer hitch (.5) to (1.0) inches from the ground on the rear of the vehicle must be present
- The trailer hitch should have a small hook to secure trailer

## TRACK SPECIFICATIONS\*

- Track surface will be BC sanded on one side, unpainted plywood
- Track width will be approximately (5.25) inches
- Side walls of track will be (3.5) inches high
- The incline will be (8) feet long at a slope of (25) degrees
- The level surface will be (4) feet in length
- Track is of rough construction with uneven surfaces, particularly at the top of the incline

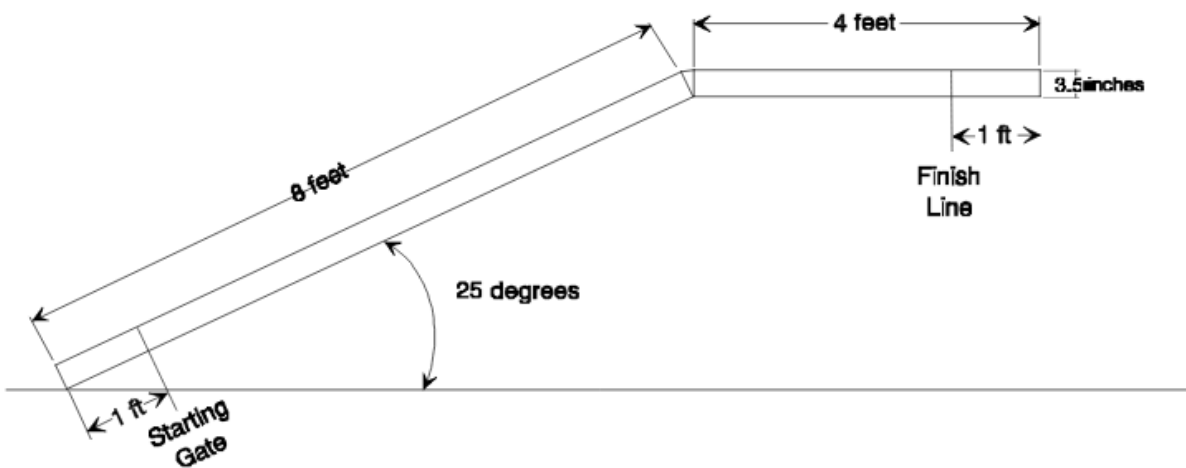

## THE TRAILER

- The exact trailer to be used has become increasingly hard to find in toy stores. Our best recommendation is to try to find something as close as possible. A photo is included below
- The pin at the front of the original trailers will be removed and replaced by a hole (.125) inches in diameter
- The trailers will be identically prepared and weighted
- Trailer and cargo will weigh approximately (6) ounces, weighted 70/30 front to back
- The trailer seen below is the original trailer that will be used in the competition.

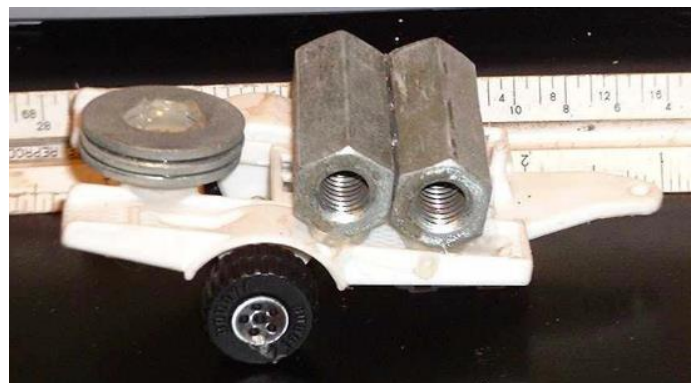

**SUPPLIES LIST (per vehicle)**

- (1) HE Hi-Speed Gear Box Assembly Kit ([www.hobbylinc.com](http://www.hobbylinc.com))
- (1) AA Battery Holder UL -Recognized Hookup Wire—need approximately 3-feet for cars without capacitors and 6-feet if using multiple capacitors
- (2) 1.5V/25mA Miniature Lamp
- (1) AA Batteries (–Need 1 to compete, but may need 2 during building/testing phase)
- (1) 400 Contact Breadboard ([www.kelvin.com](http://www.kelvin.com))
- (2) 10 Farad Super Capacitor ([www.kelvin.com](http://www.kelvin.com))
- (2) 1" Mini Wheels ([www.kelvin.com](http://www.kelvin.com))
- (1) 1 ½ Lite Flite Wheels ([www.dbproducts.com](http://www.dbproducts.com)) – Come in 2-pack
- (2) 4PDT Mini Toggle Switch ([www.parts-express.com](http://www.parts-express.com))
- (1) Competition 280 Motor ([www.kelvin.com](http://www.kelvin.com))
- (1) Stanley 10-Compartment Professional Deep Organizer ([www.homedepot.com](http://www.homedepot.com))

## **DESIGN COMPETITION (100 points)**

### **Papers (50 points)**

The one-page, typewritten report should discuss the following topics:

1. Design methodology - how/why did you choose the design you chose? Focus should be on mechanical/electrical design, not styling! (20 points)
  2. Component selection - how/why did you select components used? (15 points)
  3. Unique features - what makes your car special? (10 points)
- In addition, 5 points will be awarded for proper paper formatting (see rules below).

### **Design Presentation (50 points)**

- Prior to and during the race, each team will present their car's design to a panel of judges. Each presentation will be limited to four minutes per team, which includes question and answer time.
- Judging will be based on the following criteria:
  - 1. Ingenuity (10 points)
  - 2. Powertrain design (10 points)
  - 3. Electrical system design (10 points)
  - 4. Aesthetics (10 points)
  - 5. Overall vehicle design (5 points)
  - 6. Quality of presentation (props, delivery, adherence to time, etc.) (5 points)
- Papers must be submitted electronically as either a Word document (.doc) or as an Acrobat file (.PDF) to Roxanne Loeffler at [roxanne.loeffler@sae-detroit.org](mailto:roxanne.loeffler@sae-detroit.org) no later than COB on Monday, April 9, 2018
- Only those teams explicitly invited based on their paper score will be allowed to present their design orally. You will be notified approximately one week prior to the event
- PAPER MUST BE typed and double-spaced with one-inch margins (top, left, and right), using 10-point or larger Arial font. The heading should include: title, school's name, and each team member's name, which may appear outside the one-inch text margin (5 points will be awarded for proper formatting)
- Papers must include one email address for a team representative. This email address will be used to notify those teams that will be invited to participate in the Design Presentation. We suggest you use your teacher's email address.
- Separate trophies and monetary awards will be given to the top three competitors or teams with the highest design point totals\
- The top three finishing teams will be awarded design points towards the Overall School Final Results Competition in the following manner: First Place – (4) points, Second Place – (2) points, Third Place – (1) point

## **PERFORMANCE COMPETITION**

- The competition will run in heats, with every competitor getting at least (2) chances to advance (i. e., double-elimination)
- Up to (6) vehicles will compete at one time
- Heat setup will be based on number of entrants, prior to the competition
- A battery will be provided for each vehicle at the beginning of the competition
- Only one battery per vehicle will be used for all races except for the final race (no battery changes allowed)
- The trailer must be attached throughout the heat race
- All vehicles will start on the incline at the (1) foot mark
- A lift gate will be used to start all cars at the same time
- Prior to starting, those vehicles using capacitors or other energy storage devices will have to demonstrate that no energy is stored (capacitors will be discharged at the line)
- All storage devices (capacitors, etc.) must remain discharged until all vehicles are staged at the starting line and the command to begin charging is given by the official starter
- After 45 seconds (changed for 2018), the race official will start the race. Students should design their vehicles to reach full charge in 45 seconds. If something happens to disrupt the starting process, the race official may decide to have all vehicles discharge their stored energy and restart the charging process, but no race will be started with vehicles having more than 45 seconds of charge-time
- Competitors will turn their vehicles on (2-3) seconds before the start gate is lifted
- The finish line will be at the (3) foot mark of the level surface
- No outside interference will be allowed
- Stopping, flipping, leaving the course, or losing the trailer will result in a Did Not Finish (DNF) for that heat
- Vehicle headlights **MUST** be operational during all heats
- Competitors may only assist vehicle at the beginning of the race if the vehicle gets hung up at the start gate
- Judges decisions are FINAL
- Performance points will be awarded as follows:
  - Capacitor Class: First Place (10), Second Place (8), Third Place (6), Fourth Place (5), Fifth Place (4)
  - Non-Capacitor Class: First Place (10), Second Place (8), Third Place (6), Fourth Place (5), Fifth Place (4)
  - All ties will be decided by a run-off
  - Trophies and monetary awards (based on sponsor participation) will also be given to the top (3) finishing vehicle teams in each of the classes
-

## ➤ **CPC CAD: PROJECT-BASED LEARNING** | Micro-Electric Vehicles

### **OVERALL SCHOOL COMPETITION**

- The overall standings (for monetary awards) will be based on the Overall School Final Results Competition points total
- The Design Competition points will be added to the Performance Competition points above to determine the winning schools
- Trophies and monetary awards will be given to the top (3) finishing schools

### **GENERAL RULES (CHANGES MADE TO RULES)**

- The competition is for high school students only
- Maximum of (6) vehicles from a single school may compete, up to (3) in the “with capacitors” class and up to (3) in the “no capacitor class”. This is a change from previous competitions
- Maximum of (3) students are allowed on a single vehicle team. This is a change from previous competitions
- A single person/team may not enter more than (1) vehicle
- Failure to conform to vehicle specifications will result in disqualification from the performance competition
- If you have any questions regarding the rules, please contact Mike Arnott at [mike\\_l\\_arnott@hotmail.com](mailto:mike_l_arnott@hotmail.com)
- Design papers must be submitted via email to Roxanne Loeffler at SAE Detroit Section ([roxanne.loeffler@sae-detroit.org](mailto:roxanne.loeffler@sae-detroit.org)) by COB (Monday, April 9, 2018) to be eligible
- Teams submitting a Design paper on time will be notified prior to competition regarding their eligibility to participate in the Design Competition
- Any and all questions should be directed to competition officials onsite. Anyone disturbing competitors will be asked to leave
- NEW: Rookie Award (\$100)
  - This award is for schools who have never participated. The school with the highest number of points will win this award.
  - Schools can accumulate one (1) point per top ten (10) finish in the performance or design category. If no school places in the top ten (10), the scale will be bumped down. Ties will go to the performance event highest finisher
  - Judges decisions are FINAL
- REGISTER EARLY

### **HINTS FROM PREVIOUS COMPETITIONS**

- Wide is good
- Traction is king
- Steering does make a difference
- The track and side walls are not perfect
- Practice, practice, practice, don't forget it is double-elimination – be ready to race again even if you lose the first heat!

## **25th ANNUAL MICRO-ELECTRIC VEHICLE COMPETITION RULES**

Design Competition papers due Monday, April 9, 2018

On-Site Competition:

Wednesday, May 2, 2018

4:00 p.m. – Registration opens

5:00 p.m. – 8:00 p.m. (competition starts promptly at 5:00 p.m.)

Yazaki North America, Inc.

6801 Haggerty Road

Canton, MI 48187

For information or questions regarding the rule contact Mike Arnott at

[mike\\_l\\_arnott@hotmail.com](mailto:mike_l_arnott@hotmail.com)