

LEARNING OBJECTIVES

After completing this lesson, you will be able to:

1. Copy objects
2. Create a mirrored image
3. Add rounded corners
4. Add Chamfered corners

LESSON 7

COPY multiple copies

The **COPY** command creates a duplicate set of the objects selected.
The COPY command is similar to the MOVE command.
(Also refer to page 6-7 for an optional copy method)

The steps required are:

1. Select the objects to be copied,
2. Select a base point
3. Select a New location for the New copy.

The difference between Copy and Move commands:

The Move command merely moves the objects to a new location.

The Copy command makes a copy and you select the location for the new copy.

1. Select the Copy command using one of the following commands:

Ribbon = Home tab / Modify panel / 

or

Keyboard = CO <enter>

2. The following will appear on the command line:

Command: _copy

Select objects: ***select the objects you want to copy***

Select objects: ***stop selecting objects by selecting <enter>***

Current settings: Copy mode = Multiple

Specify base point or [Displacement/mOde] <Displacement>: ***select a base point (P1)***

Specify second point or [Array / Exit / Undo] <use first point as displacement>: ***select the new location (P2)***

Specify second point or [Array / Exit / Undo] <Exit>: ***select the new location (P2) for the next copy***

Specify second point or [Array / Exit / Undo] <Exit>: ***select the new location (P2) for the next copy or select Exit to stop.***

Refer to the example on the next page

Continued on the next page...

COPY multiple copies

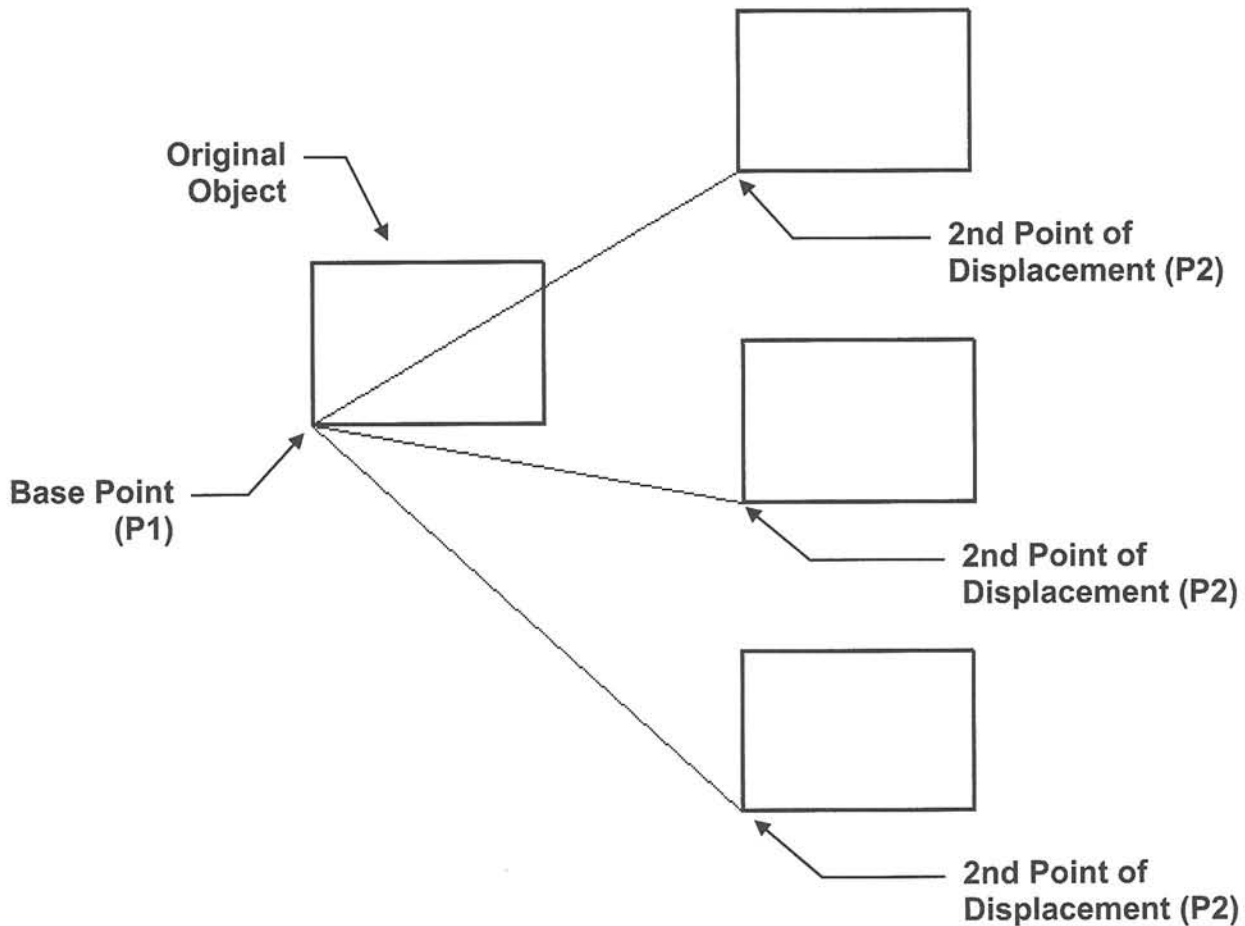

The copy command continues to make copies until you press <enter> to exit.

Changing the “Mode”

You may change the “Mode” to **Single** if you prefer to have AutoCAD stop the Copy command automatically after a single copy.

After you have selected the object(s) to copy the following prompt appears:

Current settings: Copy mode = Single
Specify base point or [Displacement/mOde] <Displacement>:

If you select the option mOde, you may select Single or Multiple copy mode.

Continued on the next page...

COPY “Array” option

The Copy command allows you to make an Array of copies.

After you have selected the Base point the following prompt appears:

Specify second point or [Array] <use first point as displacement>:

If you select the option **Array**,

1. Enter the number of items to Array <enter> 4 <enter>
2. Place 2nd Point or [Fit]: **Place 2nd point or select F <enter>**

Place 2nd Point

The space between each copy is determined by the spacing between the original base point and the 2nd point.

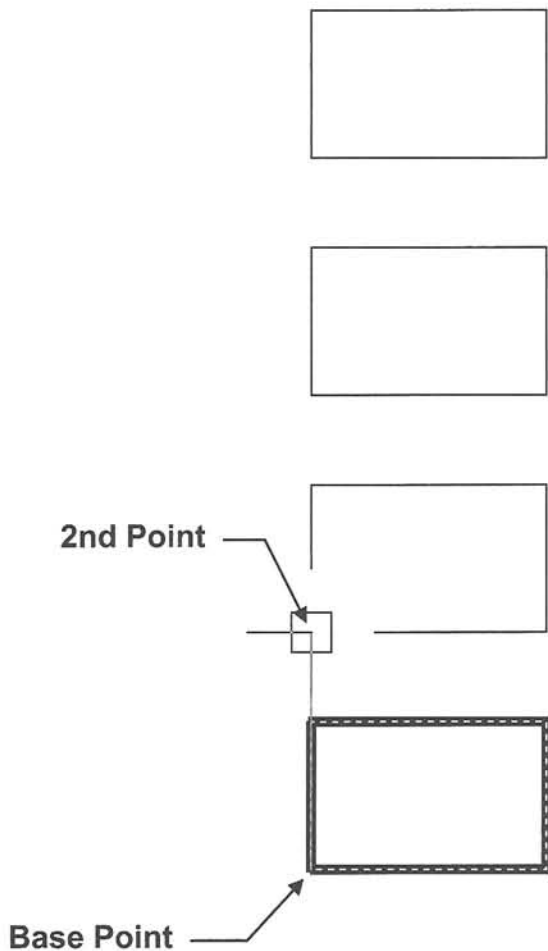

Use Fit option

The copies are evenly spaced between the Base point and the 2nd Point.

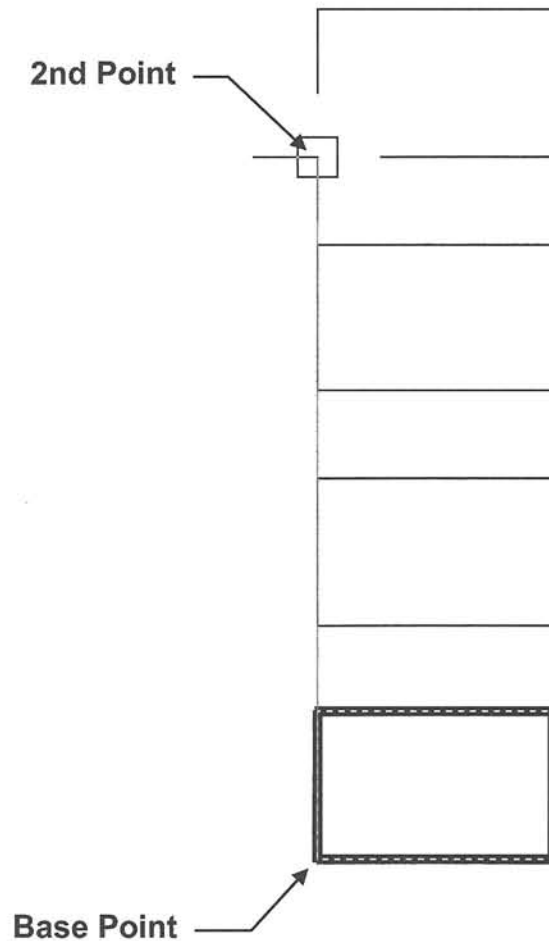

Note: The Array option within the Copy command is a quick method to create multiple copies. But AutoCAD has a more powerful and accurate Array command described in Lesson 13.

MIRROR

The **MIRROR** command allows you to make a mirrored image of any objects you select. You can use this command for creating right / left hand parts or draw half of a symmetrical object and mirror it to save drawing time.

1. Select the **MIRROR** command using one of the following:

Ribbon = Home tab / Modify panel / 

or

Keyboard = MI <enter>

2. The following will appear on the command line:

Command: `_mirror`

Select objects: ***select the objects to be mirrored***

Select objects: ***stop selecting objects by selecting <enter>***

Specify first point of mirror line: ***select the 1st end of the mirror line***

Specify second point of mirror line: ***select the 2nd end of the mirror line***

Erase source objects? [Yes/No] <N>: ***select Y or N***

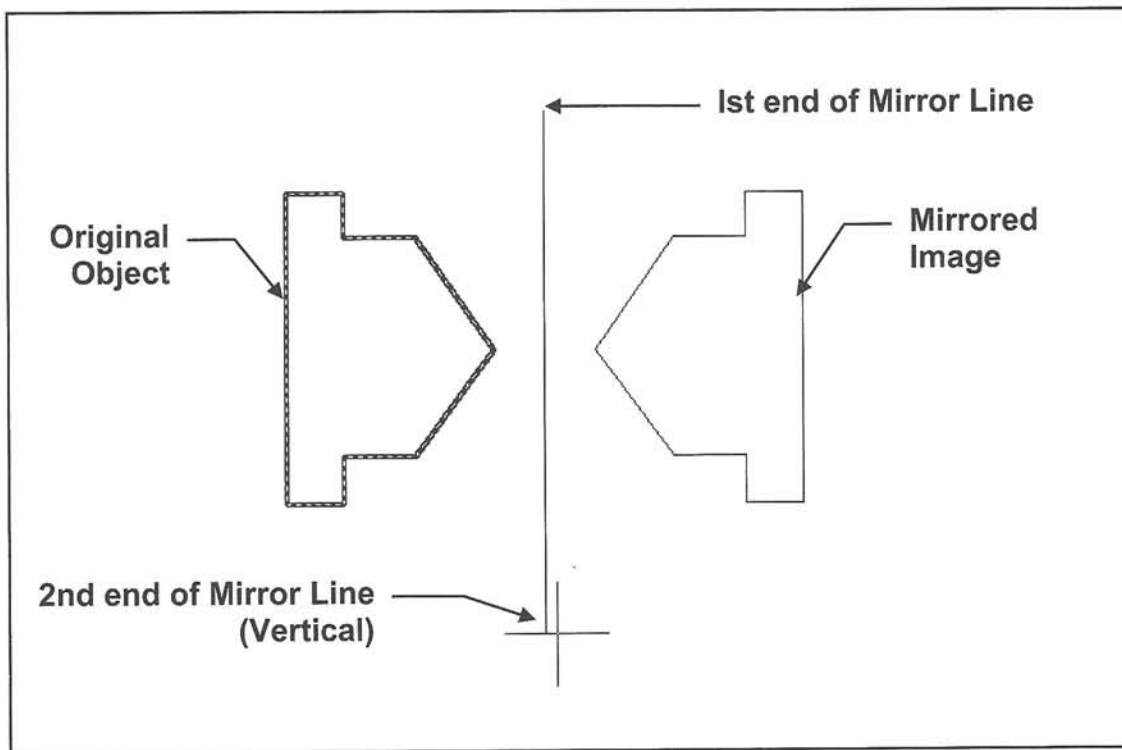

Mirror Line "Vertical"

Continued on the next page...

MIRROR....continued

Note:

The placement of the "Mirror Line" is important. You may make a mirrored copy horizontally, vertically or on an angle. See examples below and on the previous page.

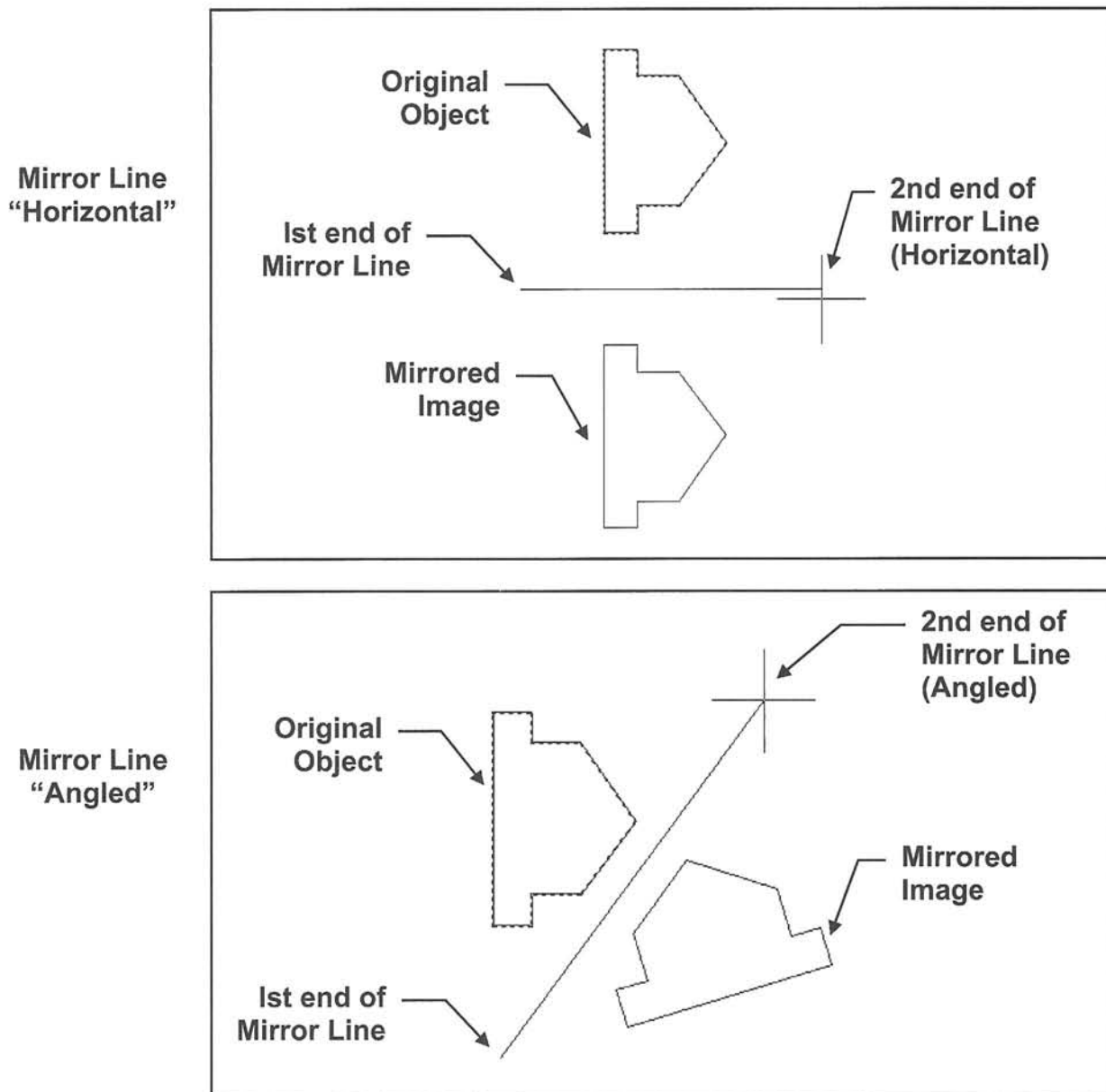

How to control text when using the Mirror command:

(Do the following **before** you use the mirror command)

1. At the command line type **mirrtext <enter>**
2. If you want the text to mirror (reverse reading): type 1 <enter>
If you do not want the text to mirror: type 0 <enter>

↑ = 0NITTE2 TX3TRIM

MIRRTEXT SETTING = 0

FILLET

The **FILLET** command will create a radius between two objects. The objects do not have to be touching. If two parallel lines are selected, it will construct a full radius.

RADIUS A CORNER

1. Select the **FILLET** command using one of the following:

Ribbon = Home tab / Modify panel / 

or

Keyboard = F <enter>

2. The following will appear on the command line:

3. **Set the radius of the fillet**

Command: `_fillet`

Current settings: Mode = TRIM, Radius = 0.000

Select first object or [Undo/Polyline/Radius/Trim/Multiple]: **type "R" <enter>**

Specify fillet radius <0.000>: **type the radius <enter>**

4. **Now fillet the objects**

Select first object or [Undo/Polyline/Radius/Trim/Multiple]: **select the 1st object to be filleted**

Select second object or shift-select to apply corner or [Radius]: **select the 2nd object to be filleted**

Note: When you place the Cursor on the second object AutoCAD displays the Fillet and allows you to change the Radius before it is actually drawn. If you choose to change the Radius, select the Radius option, enter a new radius value then select the 2nd object.

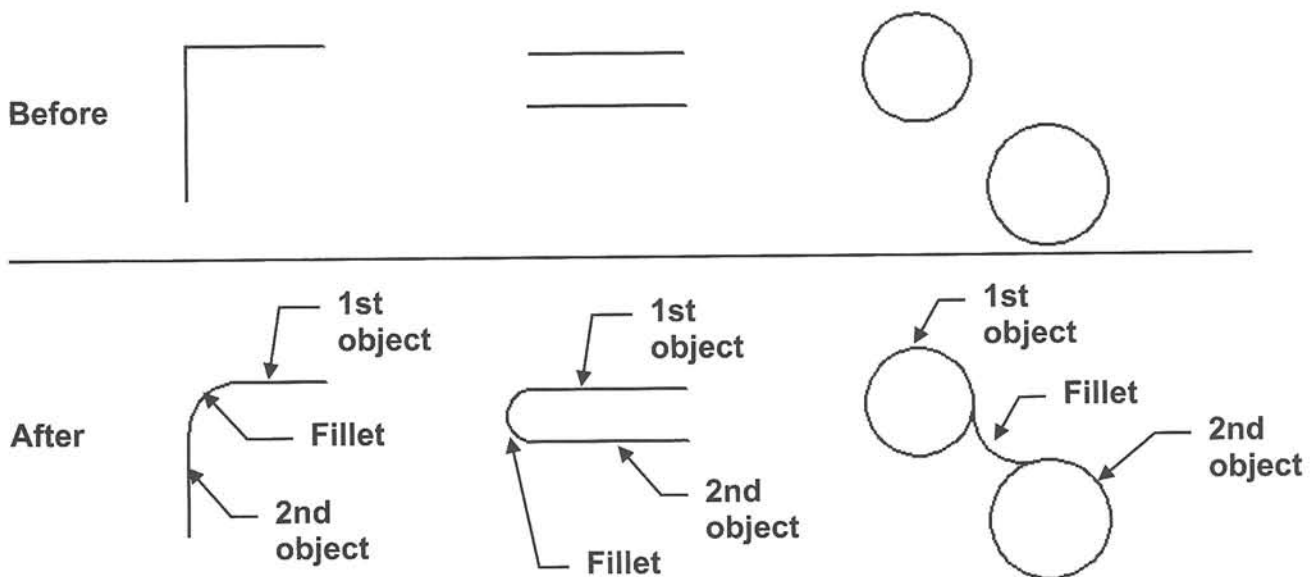

FILLET....continued

The FILLET command may also be used to create a square corner.

SQUARE CORNER

1. Select the **FILLET** command
2. The following will appear on the command line:

Select first object or [Undo/Polyline/Radius/Trim/Multiple]: ***select the 1st object (P1)***

Select second object or shift-select to apply corner: ***Hold the shift key down while selecting the 2nd object (P2)***

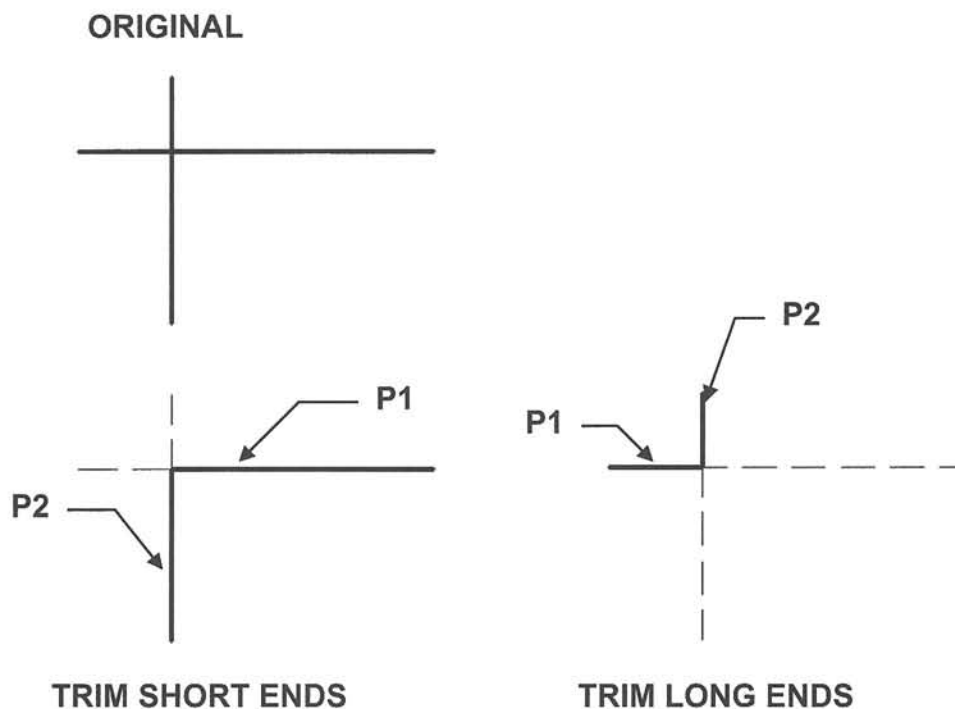

Note: The corner trim direction depends on which end of the object you select. Select the ends that you wish to keep.

OPTIONS:

Polyline: This option allows you to fillet all intersections of a Polyline in one operation, such as all 4 corners of a rectangle.

Trim: This option controls whether the original lines are trimmed to the end of the Arc or remain the original length. (Set to Trim or No trim)

Multiple: Repeats the fillet command until you press <enter> or esc key.

CHAMFER

The **CHAMFER** command allows you to create a chamfered corner on two lines. There are two methods: **Distance (below)** and **Angle (next page)**.

DISTANCE METHOD

Distance Method requires input of a distance for each side of the corner.

1. Select the **CHAMFER** command using one of the following:

Ribbon = Home tab / Modify panel /

or

Keyboard = CHA <enter>

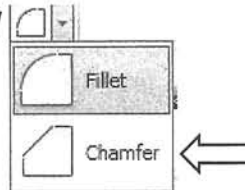

Command: `_chamfer`

(TRIM mode) Current chamfer Dist1 = 0.000, Dist2 = 0.000

Select first line or [Undo/Polyline/Distance/Angle/Trim/mEthod/Multiple]: **select "D"<enter>**.

Specify first chamfer distance <0.000>: **type the distance for first side <enter>**.

Specify second chamfer distance <0.000>: **type the distance for second side <enter>**.

2. **Now chamfer the object.**

Select first line or [Undo/Polyline/Distance/Angle/Trim/mEthod/Multiple]: **select the (First side) to be chamfered (distance 1).**

Select second line or shift-select to apply corner or [Distance/Angle/Method]: **select the (Second side) to be chamfered (distance 2).**

Note: When you place the cursor on the second side AutoCAD displays the Chamfer and allows you to change the Distances before it is actually drawn. If you choose to change the Distance, select the Distance option, enter new distance values then select the 2nd side.

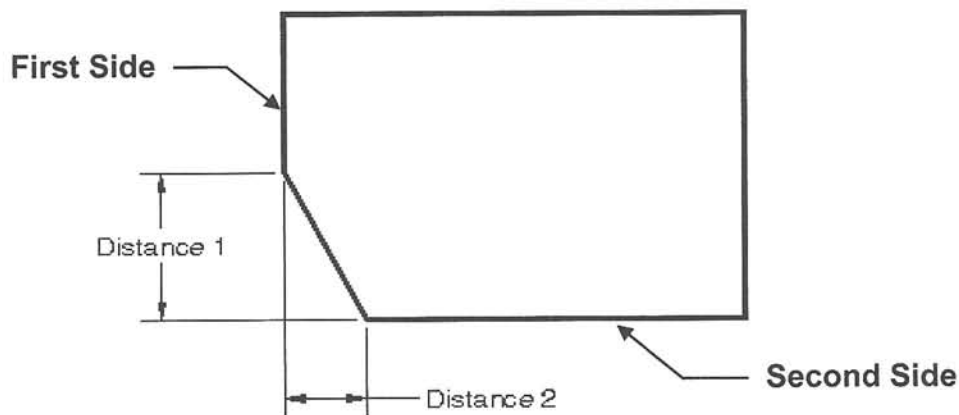

CHAMFER....continued

ANGLE METHOD

Angle method requires input for the length of the line and an angle

1. Select the **CHAMFER** command

Command: `_chamfer`

(TRIM mode) Current chamfer Dist1 = 1.000, Dist2 = 1.000

Select first line or [Undo/Polyline/Distance/Angle/Trim/method/Multiple]: **type A <enter>**

Specify chamfer length on the first line <0.000>: **type the chamfer length <enter>**

Specify chamfer angle from the first line <0>: **type the angle <enter>**

2. **Now Chamfer the object**

Select first line or [Undo/Polyline/Distance/Angle/Trim/mEthod/Multiple]: **select the (First Line) to be chamfered. (the length side)**

Select second line or shift-select to apply corner: **select the (second line) to be chamfered. (the Angle side)**

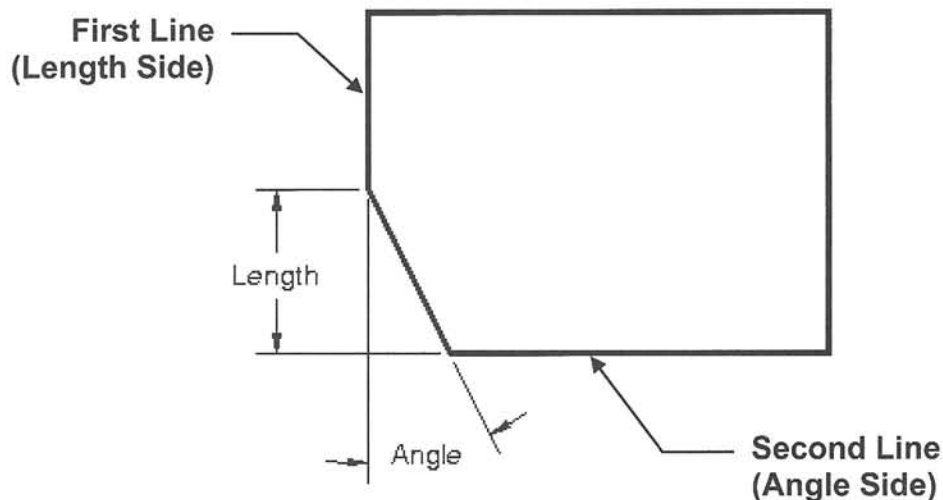

OPTIONS:

Polyline: This option allows you to Chamfer all intersections of a Polyline in one operation. Such as all 4 corners of a rectangle.

Trim: This option controls whether the original lines are trimmed or remain after the corners are chamfered. (Set to Trim or No trim.)

mEthod: Allows you to switch between **Distance** and **Angle** method. The distance or angle must have been set previously.

Multiple: Repeats the Chamfer command until you press <enter> or esc key.

EXERCISE 7A

INSTRUCTIONS:

1. Start a **NEW** file using **2013-Workbook Helper.dwt**.
2. **Draw** the Lines and one Circle shown below.

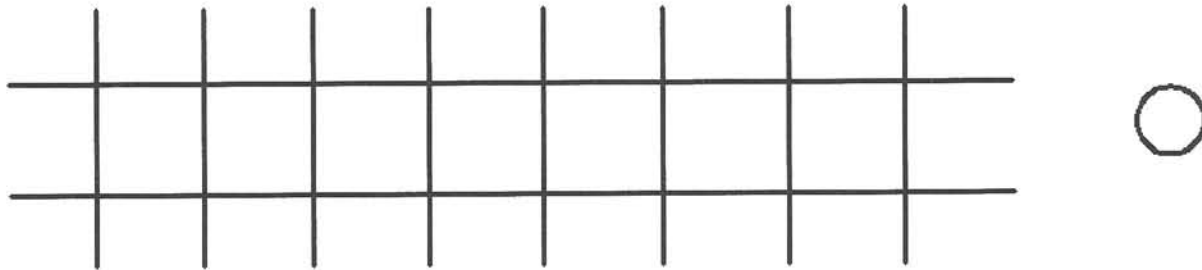

BEFORE COPY

3. Copy the Circle to all of the other locations.
 - A. Select the Copy command
 - B. Select the Circle
 - C. Select the basepoint on the Original Circle.
Note: the basepoints are different.
 - D. Select the New location (2nd point of displacement)
4. **Save** the drawing as: **EX7A**

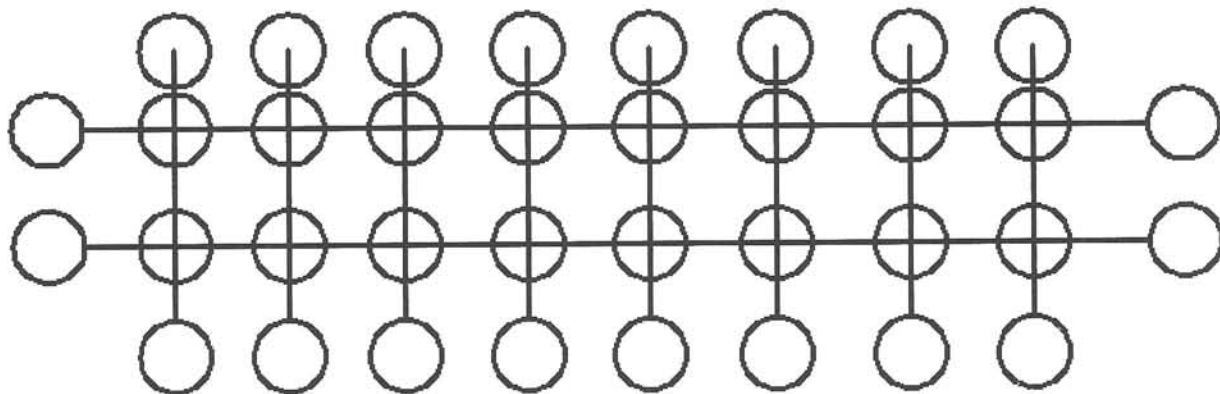

AFTER COPY

Note: Step by step instructions on the next page.

Helpful hints for 7A

1. Select the Copy command
2. Select the Circle
3. Select the Basepoint: the Center of the Circle (use object snap Center)
4. Set Running Object snap to Endpoint and Intersection and place all 24 accurately.

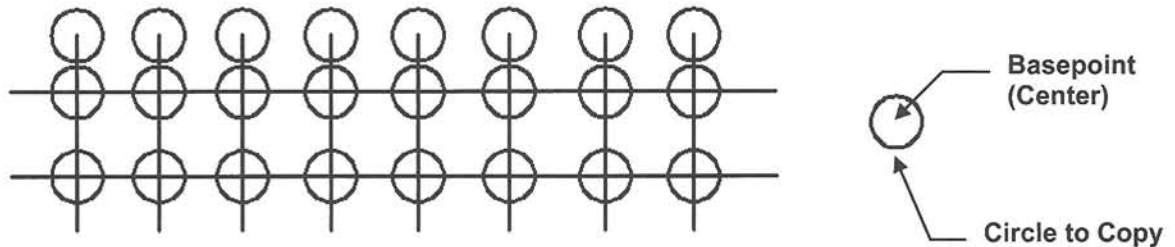

1. Select the Copy command again.
2. Select the Circle to copy
3. Select the Basepoint: the Quadrant (12 o'clock) this time.
4. Place the 8 bottom circles accurately using Endpoint object snap.

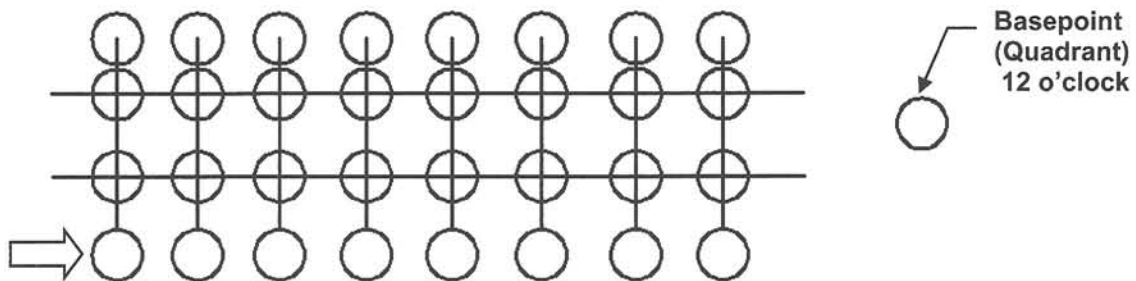

1. Select the Copy command
2. Select the Circle to copy
3. Select the Basepoint: the Quadrant (3 o'clock) this time.
4. Place the 2 circles on the left accurately using Endpoint object snap.

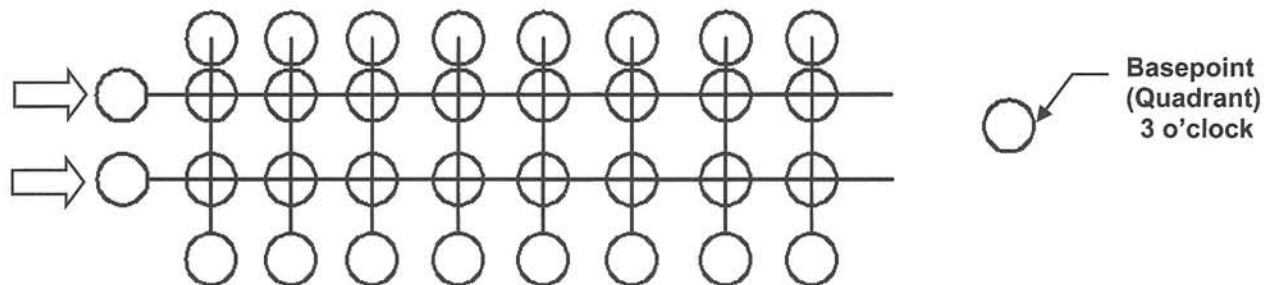

You should be able to figure out the last 2 circles on the right.

EXERCISE 7B

INSTRUCTIONS:

1. Start a **NEW** file using **2013-Workbook Helper.dwt**.
2. **Draw** the Rectangle shown below.
3. Radius the corners using the **Fillet** command.
4. **Save** the drawing as: **EX7B**

BEFORE FILLET

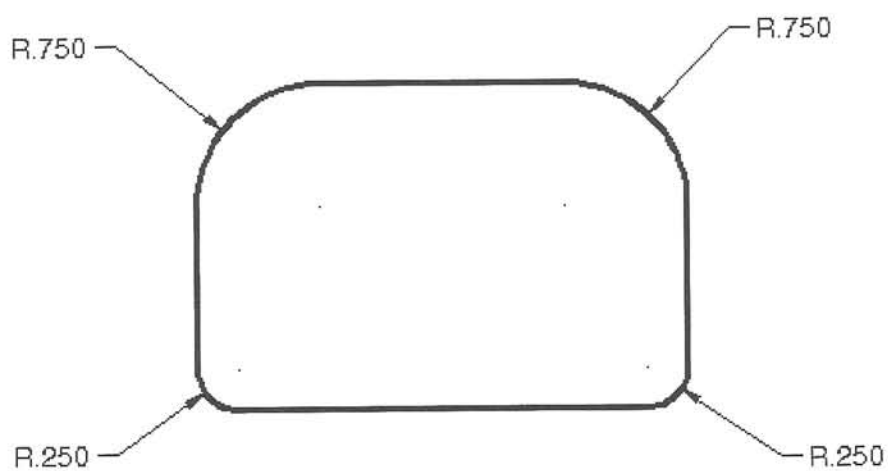
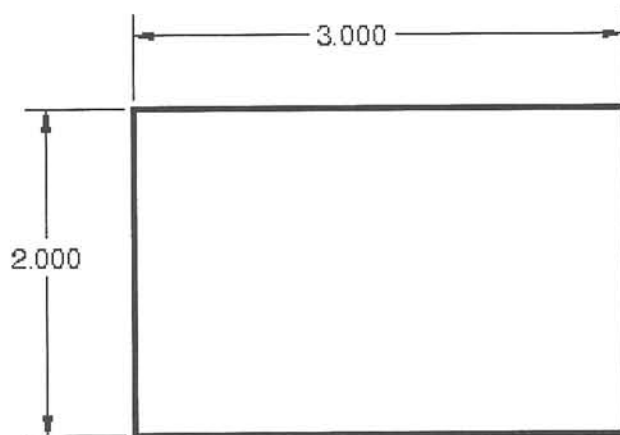

AFTER FILLET

EXERCISE 7C

INSTRUCTIONS:

1. Start a **NEW** file using **2013-Workbook Helper.dwt**.
2. **Draw** the 3 Rectangles shown below.
3. Chamfer the corners using the **Chamfer** command.
4. **Save** the drawing as: **EX7C**

BEFORE CHAMFER

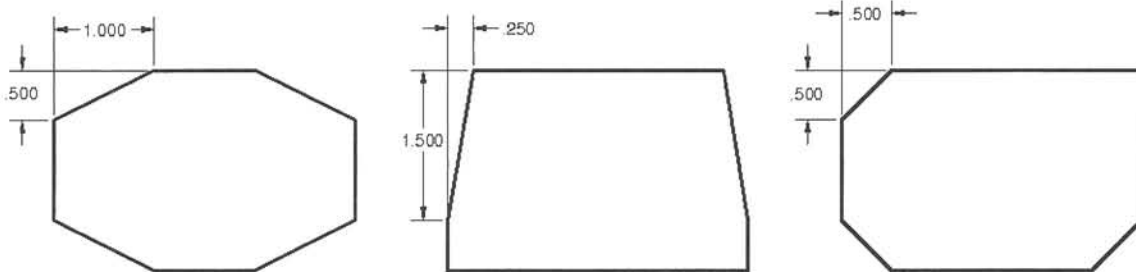
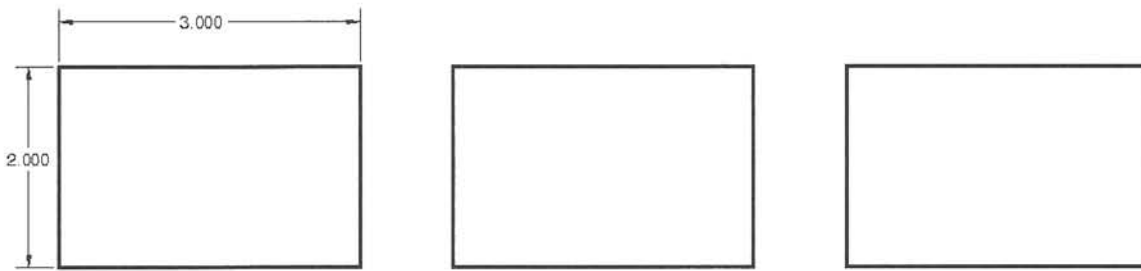

AFTER CHAMFER

EXERCISE 7D

INSTRUCTIONS:

1. Start a **NEW** file using **2013-Workbook Helper.dwt**.
2. **Draw** the Rectangle shown below.
3. Chamfer the corners using the **Chamfer** command.
4. **Save** the drawing as: **EX7D**

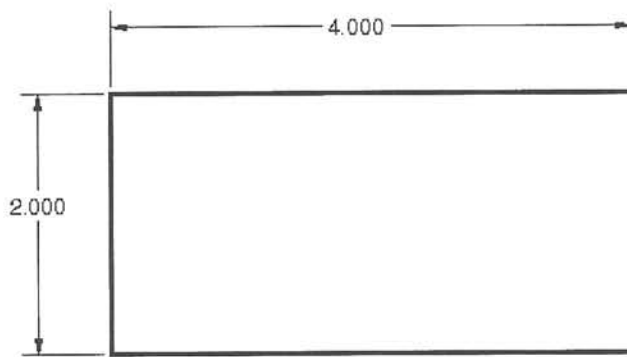

BEFORE CHAMFER

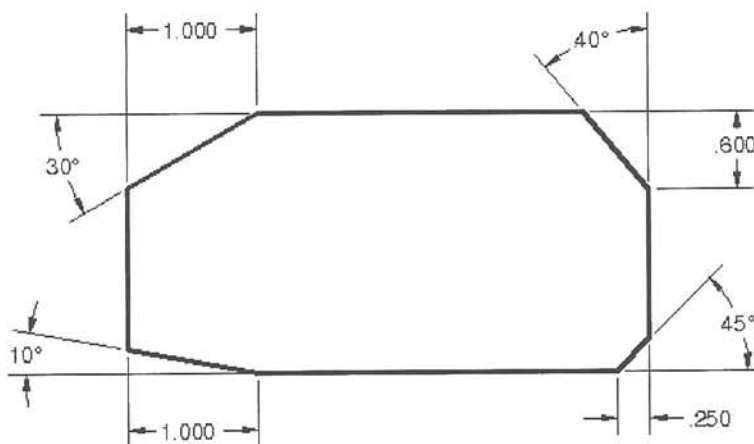

AFTER CHAMFER

EXERCISE 7E

INSTRUCTIONS:

1. Start a **NEW** file using **2013-Workbook Helper.dwt**.
2. **Draw** the "Half house shown below.
Use Layers: Roof, Wall, Window, Door, Plants and Bricks.

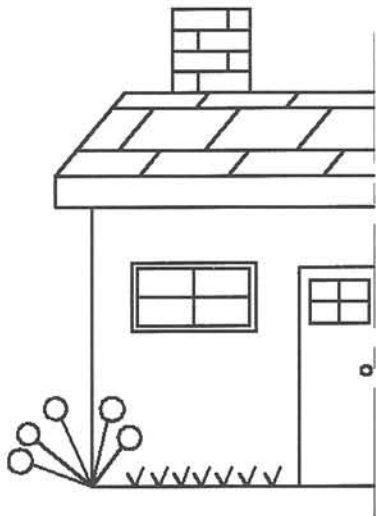

Hint: Draw this line first.
Also snap to it for the Mirror Line.
Your halves should match perfectly.

Note: You must be very accurate.
All objects must intersect perfectly.
Use ALL the commands that you have learned.
Consider Trim, Extend, Copy, Rectangle,
2 pt. Circle, Running Object snap: Nearest,
Perpendicular, Quadrant and Endpoint.
Zoom in and out.

3. Now create a Mirrored image of the half house:
 - A. Select the Mirror command
 - B. Select the objects to be Mirrored
 - C. Select the 1st endpoint of the Mirror line (Ortho ON)
 - D. Select the 2nd endpoint of the Mirror line.
 - E. Answer NO to "Erase Source Objects?"
4. **Save** the drawing as: **EX7E**

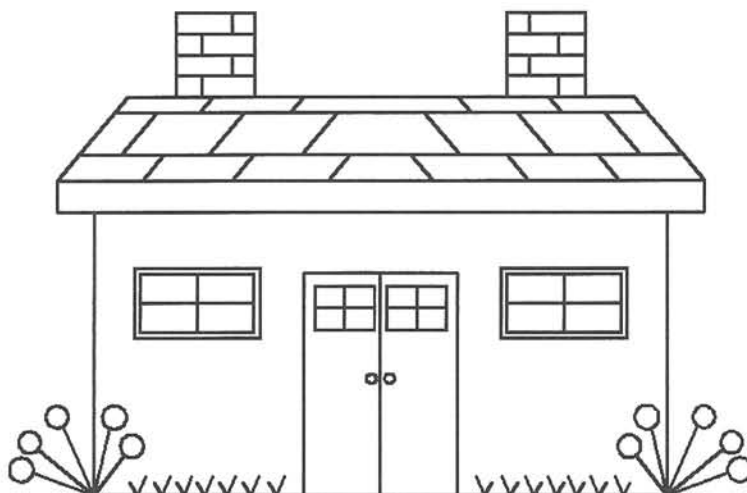

Can you imagine how
this might save you
valuable time?